

Up to 28 Gbit/s 700-890 nm High Speed Receiver Optical Subassembly (ROSA)

Product Code: R25-850

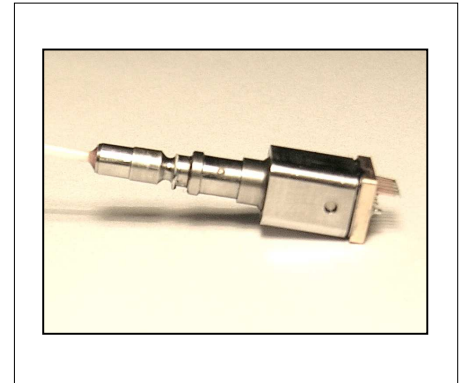

Sample image only. Actual product may vary.

Product Description

The R25-850 receiver optical subassembly (ROSA) utilizes a PIN photodetector and transimpedance amplifier (TIA) integrated in a square size 5.6mm package. The multi mode fiber coupled ROSA is designed for short reach ultrahigh-speed data communication applications of up to 28 Gbit/s. Each part is electro-optically tested to ensure a maximum performance

Preliminary

Features

- Up to 28 Gbit/s data rate
- Small size package
- Low power consumption

Applications

- Fibre Channel 32GFC
- 100G short reach interconnects
- Research and development

Parameter	Typical (PD chips)	Notes
Operating Wavelength	700 ~ 890 nm	
3 dB Bandwidth	≥ 30 GHz	
Rise time (20% to 80%)	6 ps	
FWHM Pulse Width Response	12 ps @ -2V	
Responsivity	0.4 A/W	
Dark Current	< 10 pA	
Reverse bias voltage	-2 to -4 volts	
Maximum input power	2 mW @ 850 nm	

All product specifications and descriptions are subject to change without notice.

Preliminary

Electro-optical characteristics (at Tcase = 25 °C)

Parameter	Symbol	Test Condition	Min	Typ	Max	Unit
Wavelength responsivity	λ		790	850	890	nm
Case operating temperature	T_{op}		-10		85	°C
Supply voltage	V_{cc}		3.3		3.4	V
Supply current	I_{cc}		34	45	61	mA
Bandwidth	BW			25		GHz
Low frequency cutoff					70	kHz
Sensitivity (OMA)	S			-13	-12	dBm
Output resistance	R_o			100		Ω
Optical overload			1.5			dBm
Differential output voltage	V_{out}				280	mV
Duty cycle distortion				1	10	%
Rise/Fall time	T_R / T_F		9		10	ps

Absolute Maximum Ratings

Parameter	Symbol	Min	Max	Unit
Storage temperature	T_{St}	-40	+90	°C
Lead solder temperature	T_S		260° for 10 sec	°C
Incident optical power	P_{in}		+5	dBm
Power supply voltage	V_p		4.0	V

28 Gbit/s eye pattern diagram

Preliminary

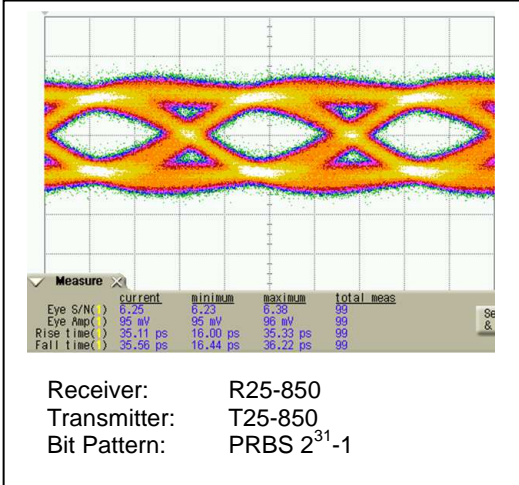

Optional adaptor board

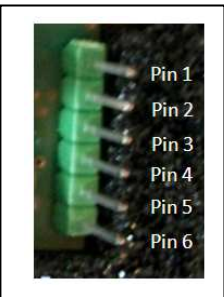
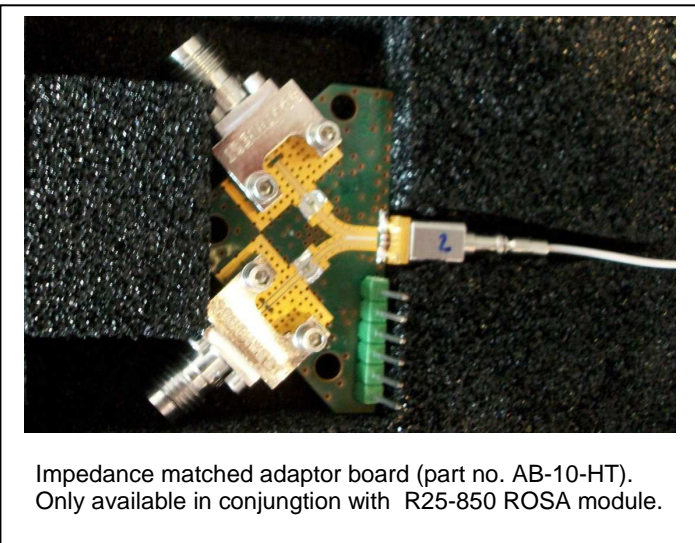

Pin #	Signal	Description
1	Vpd	supply voltage for PD
2	Vmod	output signal adjustment
3	Xing	crossing adjustment 0...3 V
4	--	not used
5	--	not used
6	Vcc	supply voltage TIA

Ground is to be supplied by the RF connectors

Preliminary

Pin out

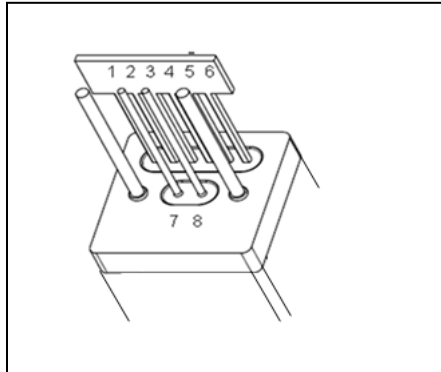

Pin #	Signal	Description
1	Vpd	Bias voltage for PD
2	Vmod	Amplitude adjustment
3	Vxing	Crossing point adjustment
4		
5	GND	Ground
6	Vcc	Supply voltage TIA
7	OUT 1	Diff. HF-output
8	OUT 2	Diff. HF-output

Dimensions

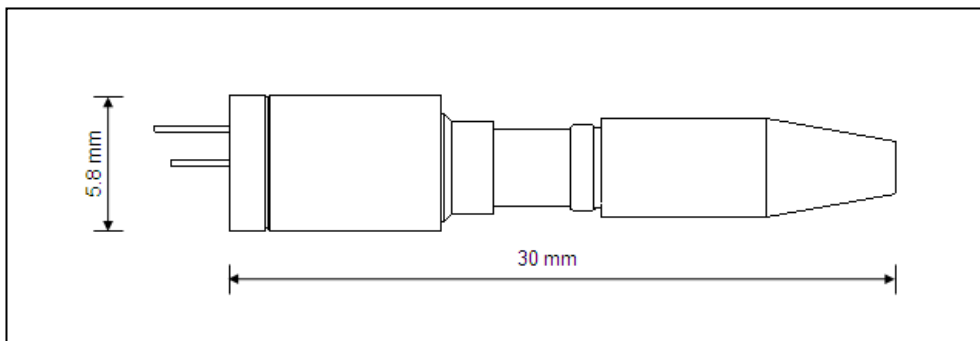

Dimensions (front)

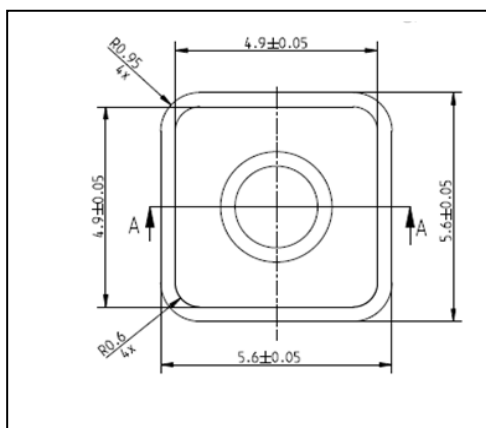

All product specifications and descriptions are subject to change without notice.
Please contact our sales department for additional information and to receive a quotation: sales@v-i-systems.com