

## High Speed (up to 40 Gbit/s) Multi-Mode Fiber-Coupled Photodetector Module (700-890 nm)

WITH FC CONNECTORIZED FIBER PIGTAIL

Product Code: D30-850M

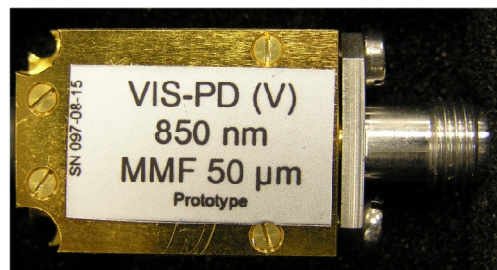

Not hermetically sealed

### Product Description

These high speed photodetector modules consist of a GaAs *pin* photodetector integrated with a 50  $\mu\text{m}$ -core diameter multimode fiber for optical input. The responsivity is greater than 0.4 A/W at 850 nm. The modules are engineering samples and use an optional external DC bias-T.

### Features

- MMF Pigtail (50  $\mu\text{m}$  core, 1 m length);
- Anritsu V electrical connector;
- FC/APC optical output connector;
- 3 dB bandwidth  $\geq 30$  GHz

### Applications

- Fiber optics systems tests
- Research and development
- VCSEL testing

Parameter	Typical	Notes
Operating Wavelength	700 ~ 890 nm	
3 dB Bandwidth	$\geq 30$ GHz	
Rise time (20% to 80%)	8 ps	
FWHM Pulse Width	17 ps	to a TiSa < 3 ps input pulse
Maximum Responsivity	0.4 A/W	
Dark Current	< 10 pA	
Reverse bias voltage	-2 to -4 volts	
Maximum input power	2 mW @ 850 nm	

### S22 magnitude

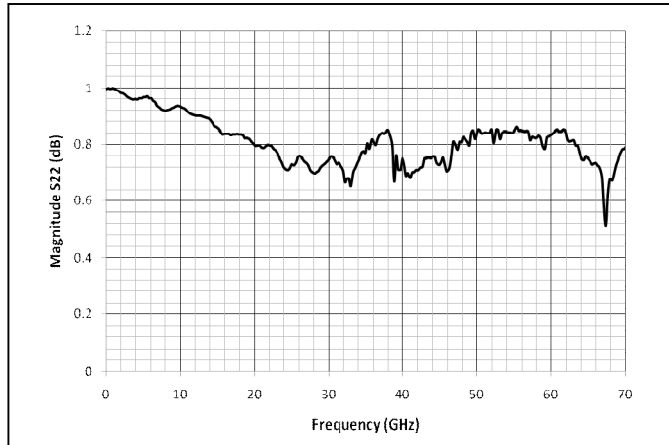

Measurement courtesy of the Institut für Festkörperphysik, TU Berlin.

### Pulse response (-2V bias)

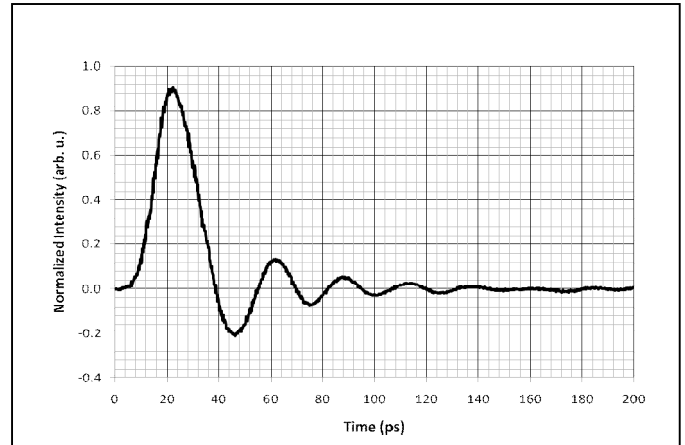

Measurement courtesy of the Institut für Festkörperphysik, TU Berlin.

### Mechanical dimensions

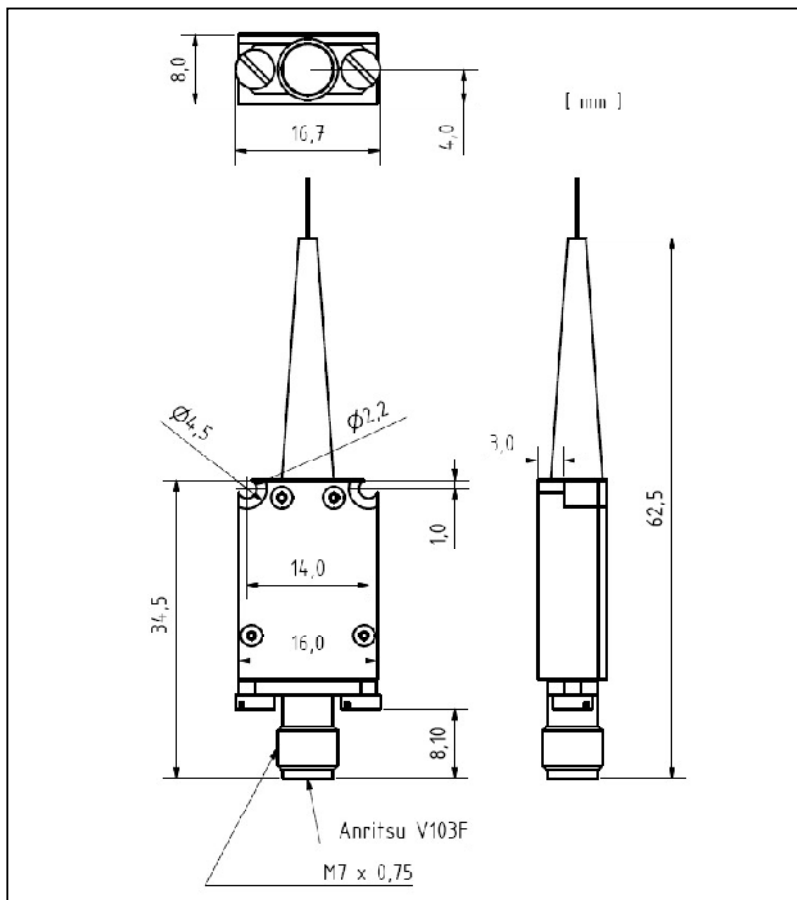

### Schematic Diagram

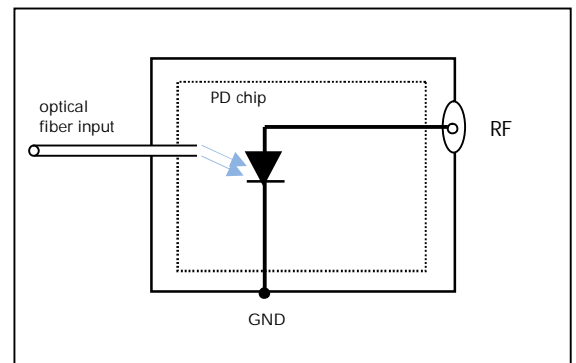

VI Systems GmbH  
Hardenbergstrasse 7  
10623 Berlin  
Tel.: +49 30 3083143 30  
Fax: +49 30 3083143 59  
[sales@v-i-systems.com](mailto:sales@v-i-systems.com)  
[www.v-i-systems.com](http://www.v-i-systems.com)

Please contact our sales department for additional information and to receive a quotation: [sales@v-i-systems.com](mailto:sales@v-i-systems.com)